

### Feature

Low lead brass ON/OFF terminal balancing valve  
 Threaded F/F (ASME B1.20.1 - NPT) or solder joint ends (ASME B16.22)  
 Tolerance on nominal Cv for fully open valve  $\pm 10\%$   
 (test according to BS7350)  
 Available on following versions:  
 - Fig. 9527AB, threaded ends  
 - Fig. 9529AB, solder joint ends  
 Provided with mounted test points  
 With threaded M30x1.5 connection for linear actuator

300WOG (max 300psi up to 160°F, max 150psi at 260°F)

Working conditions:  
 Water: from 15°F to 260°F  
 below 32°F only for water with added antifreezing fluids  
 over 212°F only for water with added anti-boiling fluids

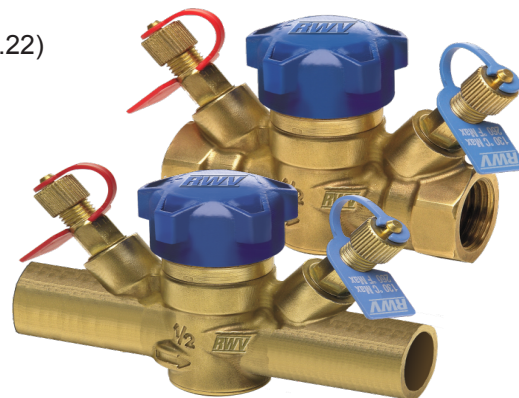

### Material

	Part	Material	Specification
1	Plug	Low lead brass	C28000
2	Body	Low lead brass	C28000
3	Disc gasket	EPDM Perox	NSF Approved
4	Gasket washer	Low lead brass	DS-561 C28500
5	Balance disc	Low lead brass	C28000
6	Stem O-ring	EPDM Perox	NSF Approved
7	Spring cartridge	Brass	B124 C37700
8	Spring	Stainless steel	
9	Disc stem	Stainless steel	
10	Stop ring	Stainless steel	
11	Washer	Brass	B124 C37700
12	Balancing stem	Low lead brass	DS-561 C28500
13	Bal. stem O-ring <sup>1</sup>	EPDM Perox	NSF Approved
14	Bonnet O-ring	EPDM Perox	NSF Approved
15	Bonnet	Low lead brass	C28000
16	Graduated scale	Blue polypropylene	-
17	Reg. indicator	Orange polyamide	-
18	ON/OFF cap	Blue polyamide	-
19	Test point / plug	DZR brass <sup>2</sup>	

<sup>1</sup> Two O-rings for sizes  $\geq 1\frac{1}{4}$ "

<sup>2</sup> Plug with copper gaskets, test points with EPDM Perox gaskets and polypropylene ties

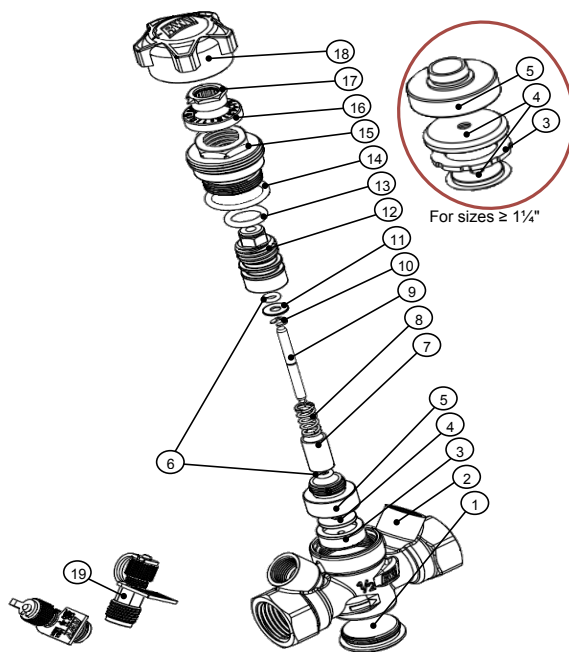

### Dimension

Size	N	ØC <sup>1</sup> [in]	L <sup>2</sup> [in]	B [in]	HB [in]	HC [in]	ØV [in]	I [in]	Valve Wt. [lb]	Act. Wt. <sup>3</sup> [lb]	Flow <sup>4</sup> [GPM]
L 1/2"	1/2"-14	0.627 - 0.631	3.3 / 3.9	0.65 / 0.51	2.0	3.6/4.03	1.6	3.9	0.77 / 0.74	0.22 / 0.24	0.49 - 1.17
1/2"	1/2"-14	0.627 - 0.631	3.3 / 3.9	0.65 / 0.51	2.0	3.6/4.03	1.6	3.9	0.77 / 0.74	0.22 / 0.24	0.98 - 2.35
3/4"	3/4"-14	0.877 - 0.881	3.5 / 4.6	0.76 / 0.78	2.0	3.6/4.03	1.6	4.1	0.99 / 0.99	0.22 / 0.24	2.19 - 5.15
1"	1"-11.5	1.128 - 1.131	3.9 / 5.0	0.90 / 0.92	2.8	4.6	1.6	4.3	1.37 / 1.27	0.24	4.09 - 9.56
1 1/4"	1 1/4"-11.5	-	4.3	0.91	4.7	5.9	1.8	4.5	2.1	0.6	8.56 - 19.81
1 1/2"	1 1/2"-11.5	-	4.7	0.91	4.7	5.9	1.8	4.9	2.7	0.6	12.84 - 29.80
2"	2"-11.5	-	5.5	1.15	5.2	6.4	1.8	5.4	3.8	0.6	24.09 - 55.63

Size	Max Δp (psi)		
	Vaurien 1	Vaurien 2	Vaurien 3
L 1/2"	51	65	-
1/2"	44	58	-
3/4"	25	36	-
1"	-	25	-
1 1/4"	-	-	41
1 1/2"	-	-	29
2"	-	-	19

<sup>1</sup> Tolerance field, version with solder ends only available up to 1"

<sup>2</sup> Threaded ends / soldering ends

<sup>3</sup> 22.5lbf RWV Vaurien 1 actuator version / 28.1lbf RWV Vaurien 2 actuator version

<sup>4</sup> Suggested flow range applicability (BS7350)

If using a measuring manometers different from those proposed by RWV please verify that sensibility of the measuring device is compatible with indicated minimum flow (see flow measurement paragraph)

Maximum working Δp of the valve when used with RWV Vaurien actuators (for more details please refer to their specific technical sheet) is indicated on the table on the left.

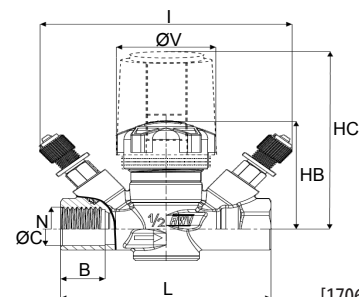

[170629]

Flow Measurement

Regulating Position	Cv (GPM/psi <sup>0.5</sup> )						
	L-1/2"	1/2"	3/4"	1"	1 1/4"	1 1/2"	2"
0.5	0.127	0.578	0.798	1.538	2.324	2.486	4.416
1.0	0.173	0.879	1.237	2.405	4.058	4.451	6.960
1.5	0.220	1.098	1.584	3.121	5.376	6.474	9.283
2.0	0.254	1.260	1.896	3.665	6.081	7.757	10.47
2.5	0.289	1.399	2.197	4.162	6.844	8.682	11.91
3.0	0.335	1.514	2.451	4.509	7.561	9.677	12.95
3.5	0.382	1.607	2.671	4.844	8.116	10.47	14.22
4.0	0.428	1.699	2.856	5.226	8.786	11.46	15.49
4.5	0.486	1.769	3.017	5.491	9.191	12.14	16.53
5.0	0.543	1.838	3.179	5.723	9.896	12.95	17.69
5.5	0.601	1.884	3.306	5.942	10.27	13.41	18.61
6.0	0.659	1.931	3.422	6.127	10.96	13.99	19.42
6.5	0.717	1.965	3.526	6.312	11.45	14.34	20.23
7.0	0.775	2.000	3.619	6.555	12.14	14.80	21.04
7.5	0.832	2.035	3.700	6.740	12.60	15.26	21.85
8.0	0.879	2.058	3.792	6.937	12.95	15.72	22.66
8.5	0.925	2.081	3.873	7.087	13.30	16.07	23.47
9.0	0.960	2.104	3.942	7.145	13.76	16.76	24.16
9.5	0.994	2.116	4.012	7.283	14.34	17.34	24.97
10.0	-	-	-	-	-	-	25.55
10.5	-	-	-	-	-	-	26.24
11.0	-	-	-	-	-	-	26.59
11.5	-	-	-	-	-	-	27.17
12.0	-	-	-	-	-	-	27.40
12.5	-	-	-	-	-	-	27.86
13.0	-	-	-	-	-	-	28.09
13.5	-	-	-	-	-	-	28.79
14.0	-	-	-	-	-	-	29.13
14.5	-	-	-	-	-	-	29.83
15.0	-	-	-	-	-	-	30.17

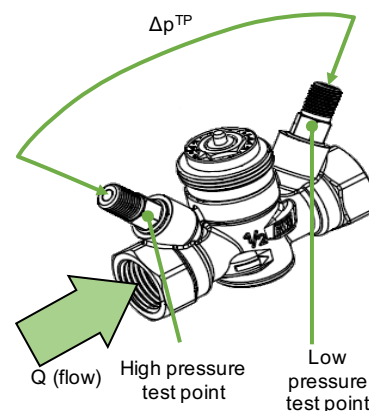
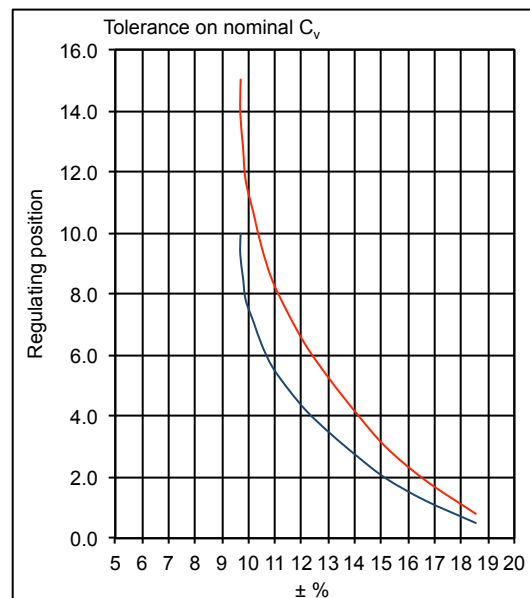

The 2" valve has a stroke of one and a half turns. The regulating value on the half turn is equal to that indicated by the arrow + 10 (see picture below).

$$Q = C_v \cdot \sqrt{\Delta p^{TP}}$$

Formula linking flow Q (in GPM) and Δp measured at test points (in psi). Cv depends on regulating position as indicated on table.

Minimum flow that can be measured for each diameter may be calculated by using in the formula minimum Δp that can be measured by used manometer.

Valves are anyway designed for best performances when used on range previously suggested and as indicated by BS7350.

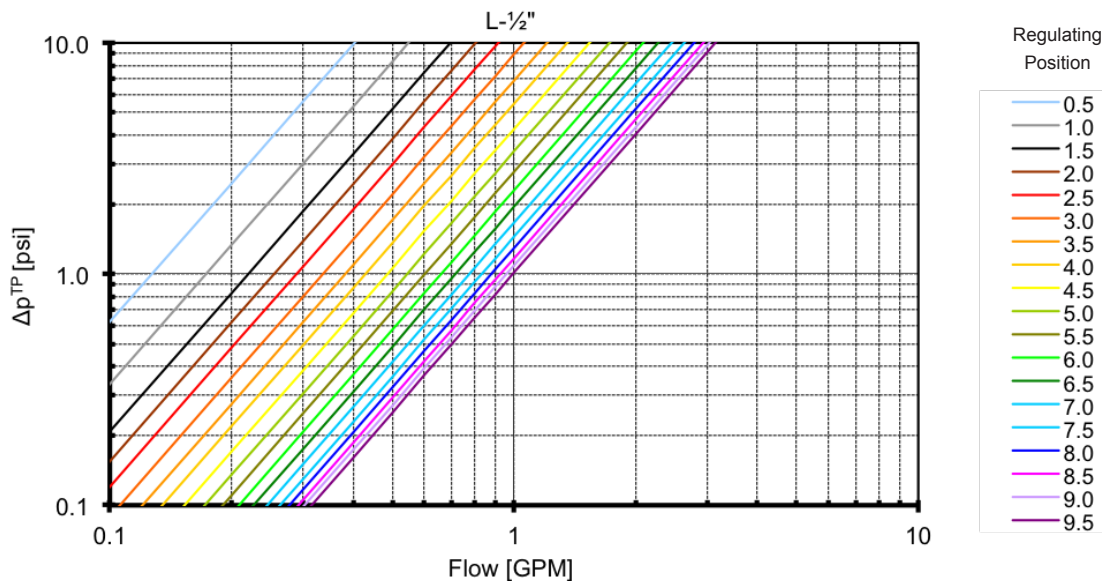

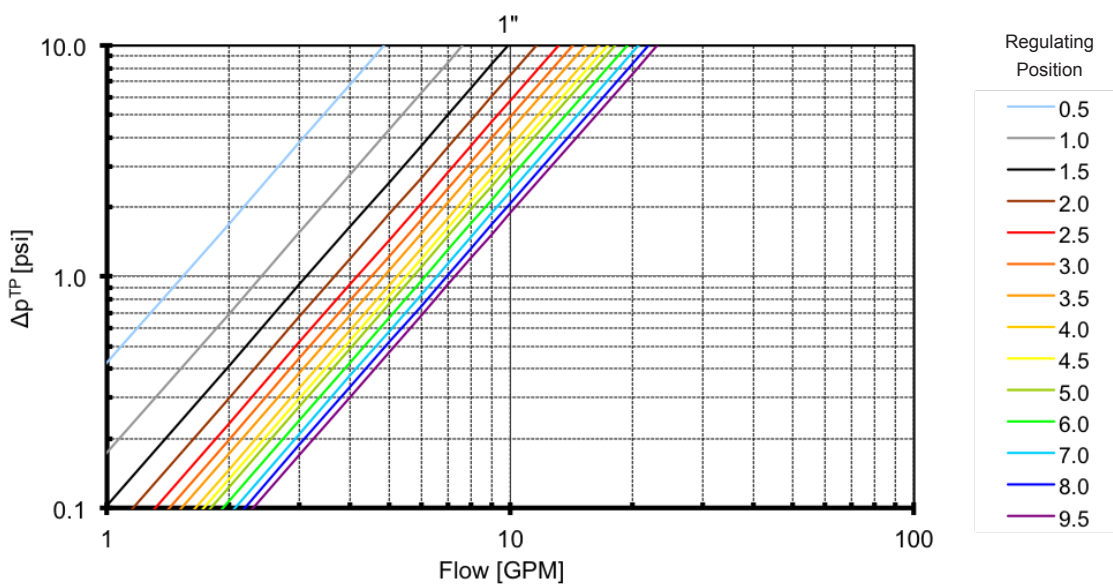
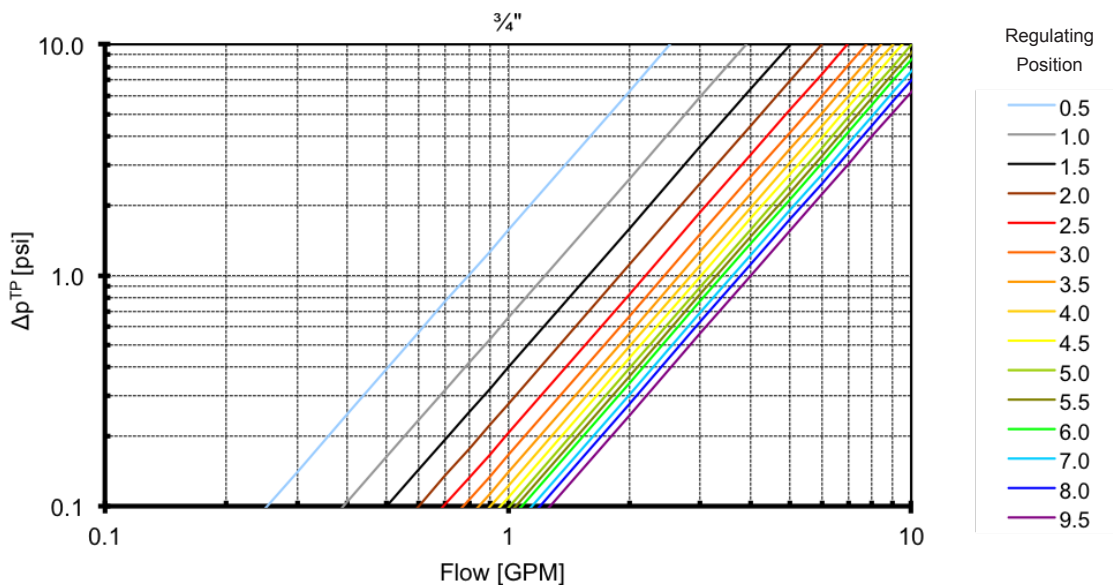
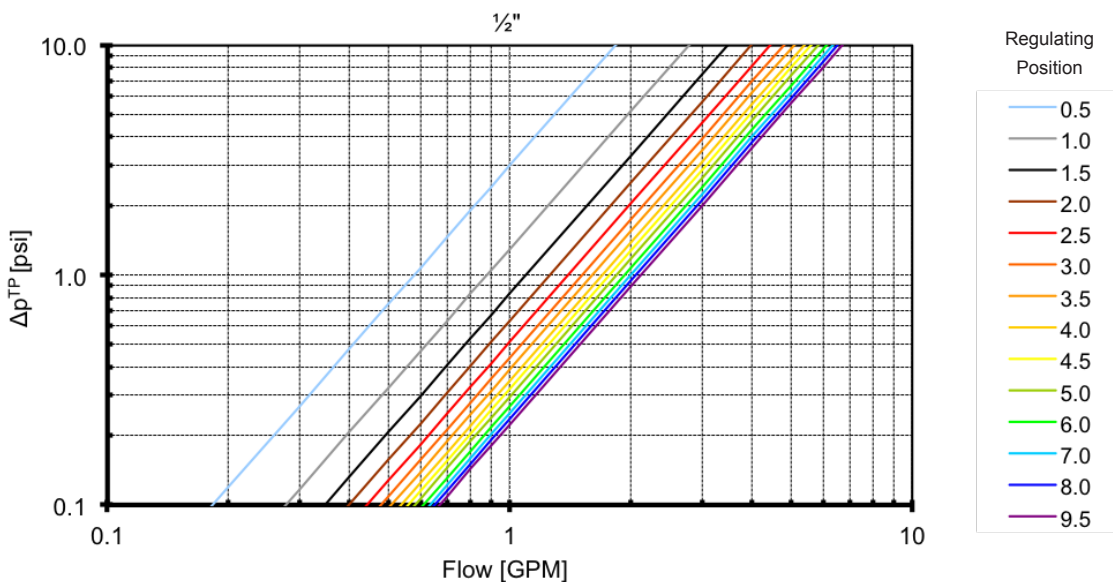

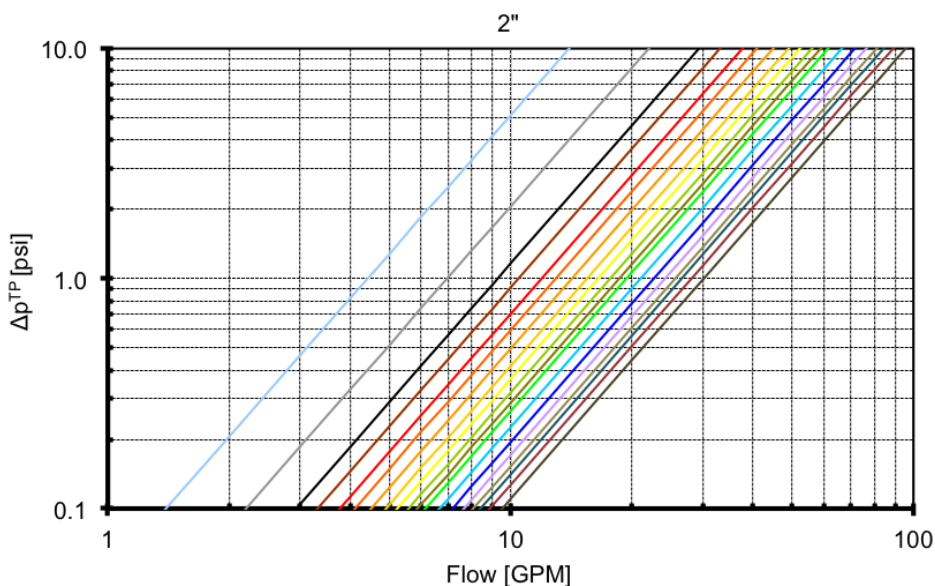
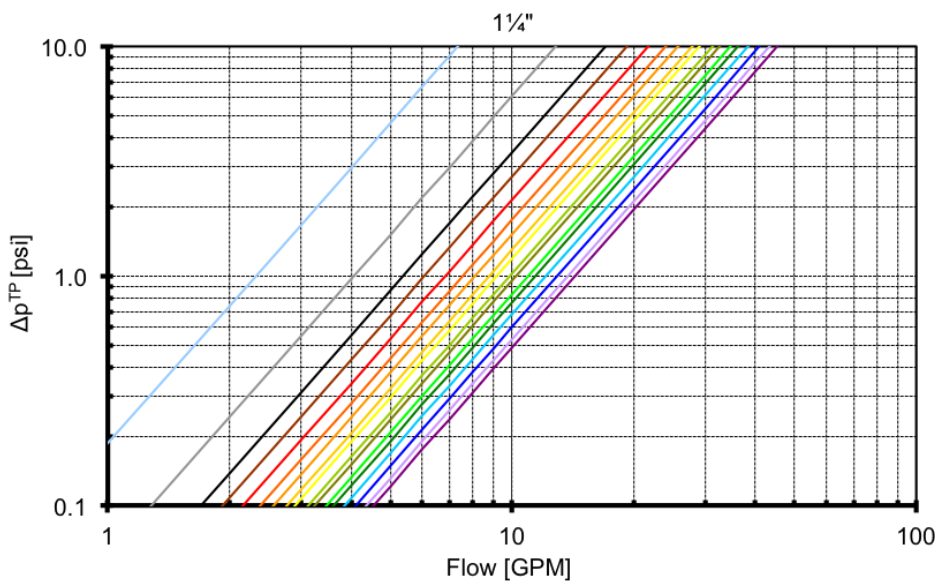
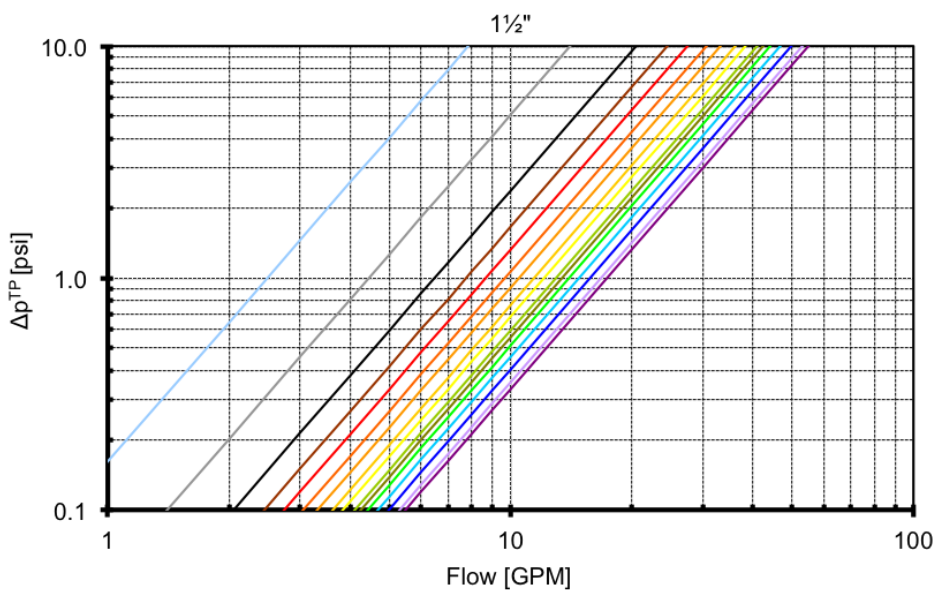

### Headloss Calculation

Regulating Position	Cv (GPM/psi <sup>0.5</sup> )						
	L-½"	½"	¾"	1"	1¼"	1½"	2"
0.5	0.127	0.578	0.798	1.538	2.324	2.486	4.416
1.0	0.173	0.879	1.237	2.405	4.058	4.451	6.960
1.5	0.220	1.098	1.584	3.121	5.376	6.474	9.283
2.0	0.254	1.260	1.896	3.665	6.081	7.757	10.47
2.5	0.289	1.399	2.197	4.162	6.844	8.682	11.91
3.0	0.335	1.514	2.451	4.509	7.561	9.677	12.95
3.5	0.382	1.607	2.671	4.844	8.116	10.47	14.22
4.0	0.428	1.699	2.856	5.226	8.786	11.46	15.49
4.5	0.486	1.769	3.017	5.491	9.191	12.14	16.53
5.0	0.543	1.838	3.179	5.723	9.896	12.95	17.69
5.5	0.601	1.884	3.306	5.942	10.27	13.41	18.61
6.0	0.659	1.931	3.422	6.127	10.96	13.99	19.42
6.5	0.717	1.965	3.526	6.312	11.45	14.34	20.23
7.0	0.775	2.000	3.619	6.555	12.14	14.80	21.04
7.5	0.832	2.035	3.700	6.740	12.60	15.26	21.85
8.0	0.879	2.058	3.792	6.937	12.95	15.72	22.66
8.5	0.925	2.081	3.873	7.087	13.30	16.07	23.47
9.0	0.960	2.104	3.942	7.145	13.76	16.76	24.16
9.5	0.994	2.116	4.012	7.283	14.34	17.34	24.97
10.0	-	-	-	-	-	-	25.55
10.5	-	-	-	-	-	-	26.24
11.0	-	-	-	-	-	-	26.59
11.5	-	-	-	-	-	-	27.17
12.0	-	-	-	-	-	-	27.40
12.5	-	-	-	-	-	-	27.86
13.0	-	-	-	-	-	-	28.09
13.5	-	-	-	-	-	-	28.79
14.0	-	-	-	-	-	-	29.13
14.5	-	-	-	-	-	-	29.83
15.0	-	-	-	-	-	-	30.17

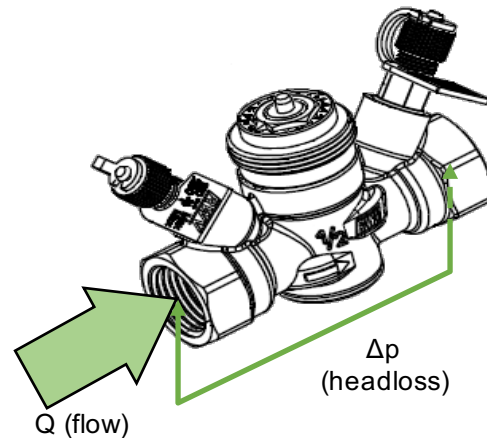

$$\Delta p = \left( \frac{Q}{C_v} \right)^2$$

Formula linking flow Q (in GPM) and Δp measured at test points (in psi). Cv depends on regulating position as indicated on table.

### Installation

Regulation is done by removing the ON/OFF cap and acting on regulation indicator with the provided regulating key, for sizes 1¼" and larger the key is attached to the ON/OFF cap. Once desired regulation is obtained screw on the cap (gently with the only aim to fix it to the valve, do not apply force!).

It's possible at any time to act on the ON/OFF cap to completely close the valve, independently from regulation. To do so act on the cap screwing it on at full stroke.

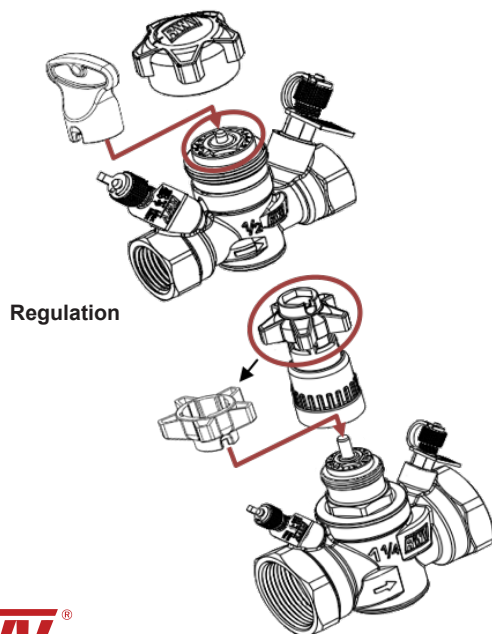

Regulation

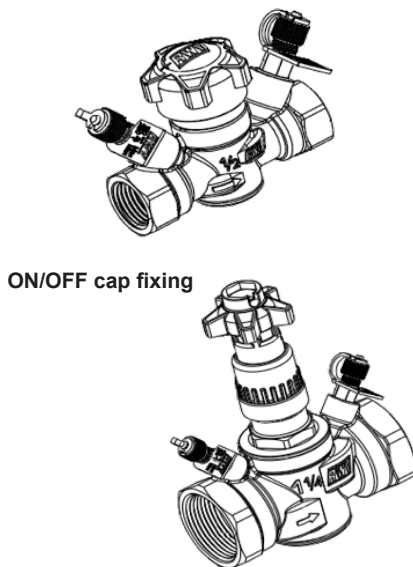

ON/OFF cap fixing

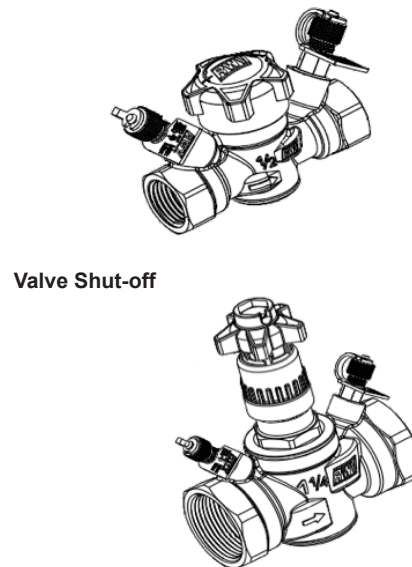

Valve Shut-off

To obtain the best performances valve must be installed on a pipe with its same nominal size preceded and followed by straight pipe lengths as per figure indications.

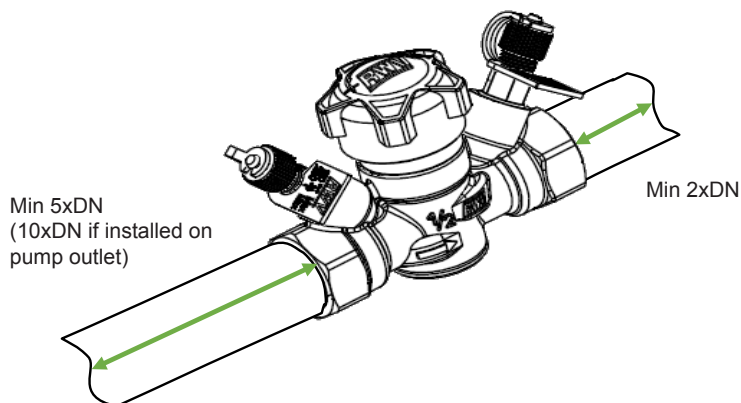

It is possible, at any time and even after the installation of the valve onto the line, to install onto the 9520 valve series a linear Vaurien actuator (for more information please refer to its specific technical sheet).

Remove the ON/OFF cap and fix the adaptor onto the valve (making sure you select the appropriate one for the valve diameter as per figure below), tighten by hand in a clock-wise direction thus avoiding the use of any additional tools.

For valves up to 1" (included) fix the actuator onto the adaptor by simply pressing the two parts together. Should it be necessary to remove the actuator, for example to set a new regulation on the graduated scale, press the unblock button and simply pull the actuator off without unscrewing the adaptor from the valve.

For valves 1 1/4" and larger screw the actuator on the adaptor. Simply unscrew it if in need to remove it.

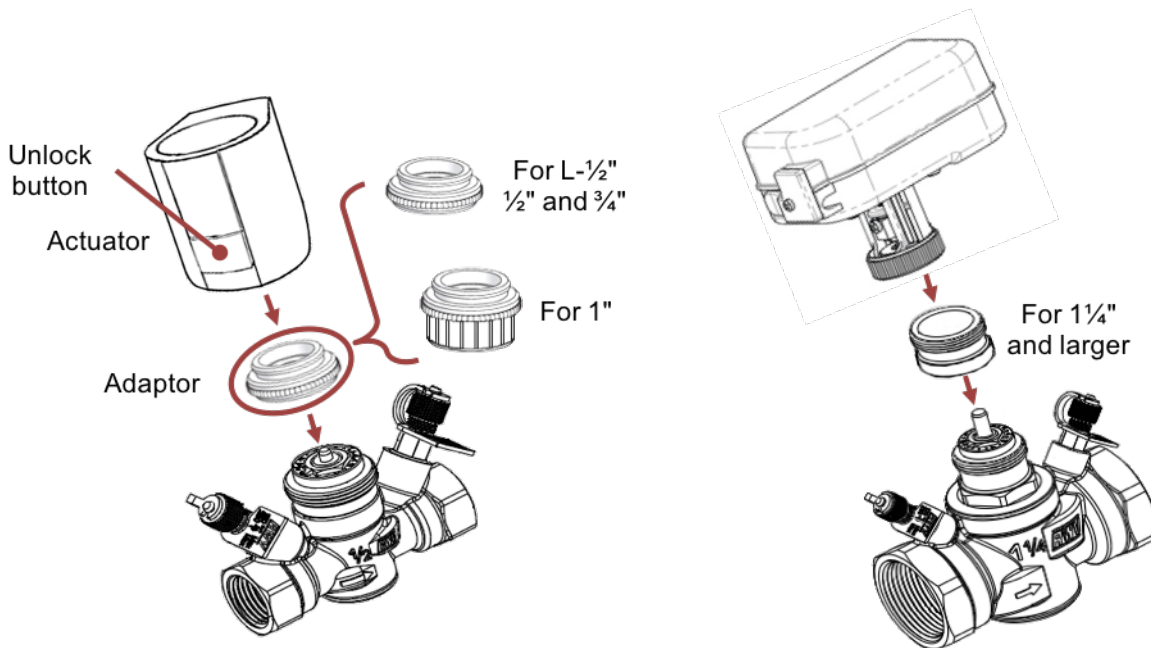

**Presetting**

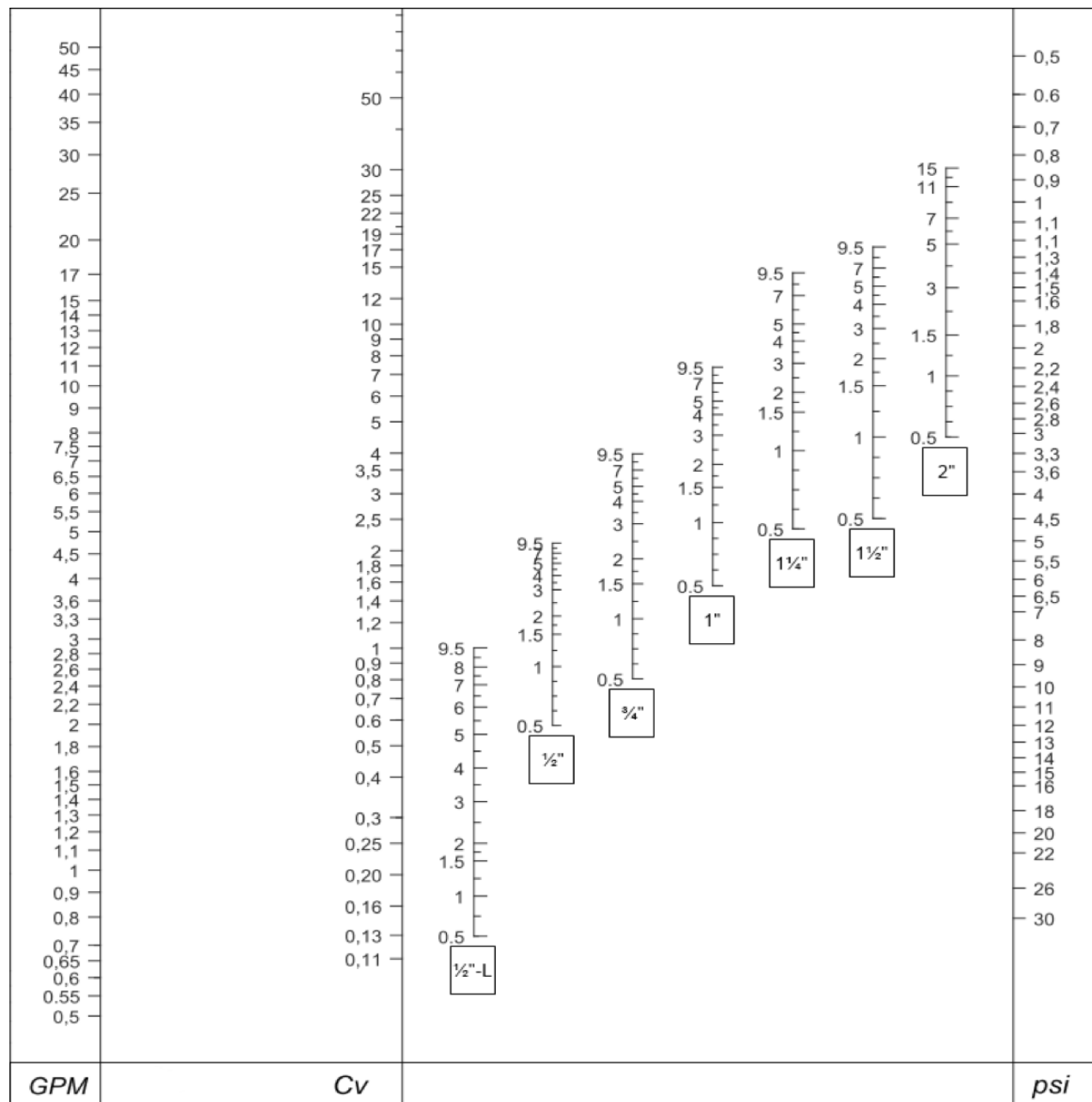

By using the diagram above, it is possible to evaluate the presetting position of the valve with given design flowrate and headloss:

- 1) draw a straight line joining design flowrate and design headloss;
- 2) determine design Cv value as intersection of drawn line and Cv axis;
- 3) draw a straight horizontal line from intersection previously identified and the specific valve DN Axis;
- 4) intersection determines handwheel position to use for presetting.

In the example for a design flowrate of 4GPM and design  $\Delta p$  3psi handwheel position of 2,7 is determined for a 1/2" valve

