

Features

- 31-7/8H, 19-1/8W, 15-7/8D
- Cartridge-free waterless urinal functionality
- Saves up to 40,000 gallons of water per fixture per year and significantly reduces sewage and maintenance costs
- Cartridge-free integral trapway provides enhanced performance and less maintenance
- Optimized interior design virtually eliminates splashing
- Touch-free design is vandal resistant and offers added hygiene to users
- This product can help a building earn Water Efficiency points in LEED® Green Building Rating System

Material

- Vitreous china

Recommended Products/Accessories

- 1048656 Sealing Liquid 128 oz
- 1048656-P Sealing Liquid - Case
- 1174866 Waterless Urinal Cleaner 3-Pack
- K-4929 Waterless Urinal Maintenance Balls



ADA

Codes/Standards

ASME A112.19.2/CSA B45.1
ASME A112.19.19
ADA
ICC/ANSI A117.1

KOHLER® One-Year Limited Warranty

See website for detailed warranty information.

Available Colors/Finishes

Color tiles intended for reference only.

Color	Code	Description
-------	------	-------------

	0	White
---	---	-------

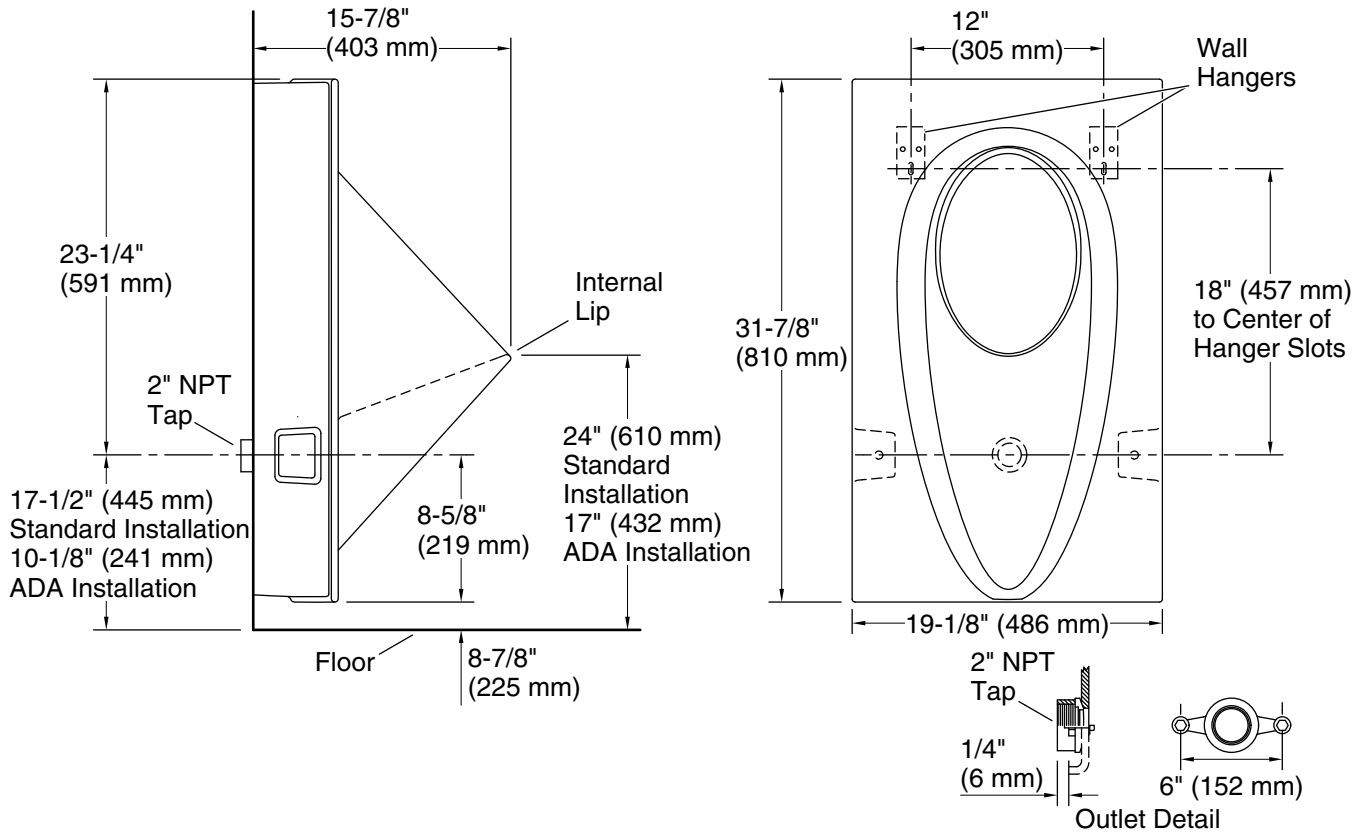

Technical Information

All product dimensions are nominal.

Spud size: 2", Outlet, Rear

Min. Water per Flush: 0 gpf (0 lpf)

Max. Water per Flush: 0 gpf (0 lpf)

Designed for the above water use when installed with a water-saving flushometer.

Notes

Install this product according to the installation guide.

Product dimensions are nominal and may vary per ASME A112.19.2 tolerances.

CAUTION: Risk of property damage. When connecting waterless urinals to the building drain waste vent system, do not use copper pipe or copper tube connectors. The use of a copper connector will result in corrosion of the connector and potential building structure damage caused by leakage.

ADA compliant when installed to the specific requirements of these regulations.