



# Underscore®

60" x 30" alcove VibrAcoustic® bath with Bask® heated surface, right drain  
**K-1167-VBRW**

## Features

- Six concealed speakers send sound waves through the water to gently massage the body
- Six original instrumental compositions offer different levels of relaxation
- Syncs with devices enabled with BLUETOOTH® wireless technology including smartphones, MP3 players, tablets, and laptops located up to 33 feet away.\*
- Customize your experience with the high-resolution color touch screen
- Fully-adjustable volume above and below the water
- Functions as a hydrotherapy bath when full of water and a stereo system when empty
- Bask® heated surface creates spa-like relaxation with soothing warmth on your back, shoulders, and neck
- Three heat settings allow you to customize the surface temperature
- Slotted overflow allows for deep soaking
- Integral flange helps prevent water from seeping behind wall and simplifies alcove installation
- Includes 25' of wiring and amplifier

## Material

- Acrylic

## Technology

- VibrAcoustic calms and soothes with sound vibration technology

## Installation

- Right drain
- Alcove
- Requires 110 V electrical service

## Required Products/Accessories

K-7271 Brass Slotted Overflow Bath Drain

or

K-7272 PVC Slotted Overflow Bath Drain

## Recommended Products/Accessories

- 1184460 Undermount installation kit
- K-531 Under-Mount Installation Kit
- K-1177 Vinyl Tiling-in Bead
- K-23726 Drain treatment
- K-23732 Tub & shower cleaner
- K-31797 Slotted overflow bath drain kit
- K-31795 Slotted overflow above-the-floor bath drain kit



**ADA**

## Codes/Standards

CSA B45.5/IAPMO Z124  
ASTM E162  
ASTM E662  
UL 1795  
CSA C22.2 No. 218.2  
ADA  
ICC/ANSI A117.1  
IAPMO Certification  
cUL Listed  
UL Listed

## KOHLER® Plastic Baths and Shower Bases Lifetime Limited Warranty KOHLER® Hydrotherapy Components Five-Year Limited Warranty

See website for detailed warranty information.

The BLUETOOTH® word mark and logos are registered trademarks owned by Bluetooth SIG, Inc. and any use of such marks by Kohler Co. is under license. Other trademarks and trade names are those of their respective owners.

1-800-4KOHLER (1-800-456-4537)

Kohler Co. reserves the right to make revisions without notice to product specifications.

For the most current Specification Sheet, go to [www.kohler.com](http://www.kohler.com) USA or [www.kohler.ca](http://www.kohler.ca) Canada

2-28-2024 20:28 - US

THE BOLD LOOK  
OF **KOHLER®**

No change in measurement if connected with drain illustrated. (K-7272)

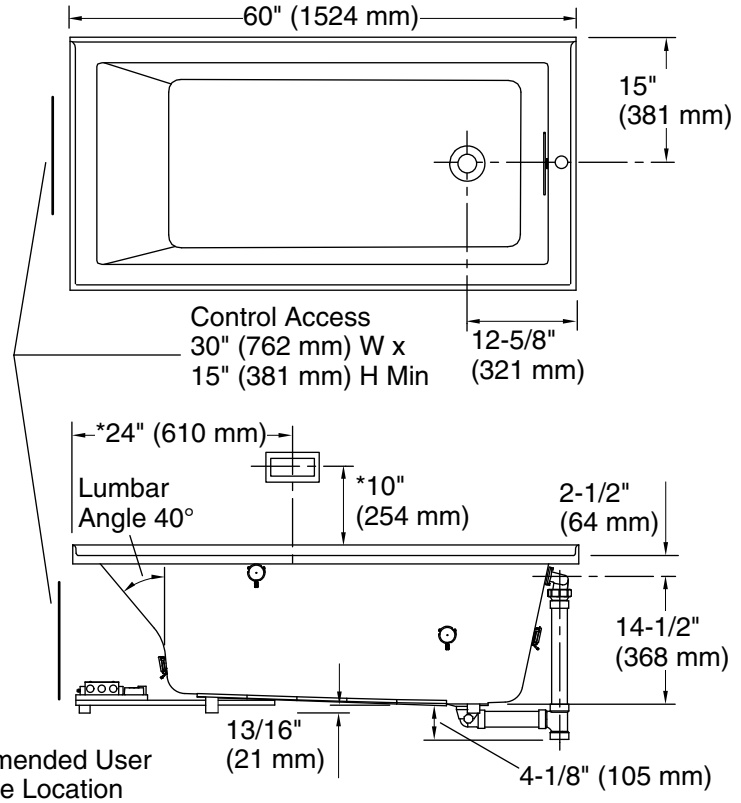
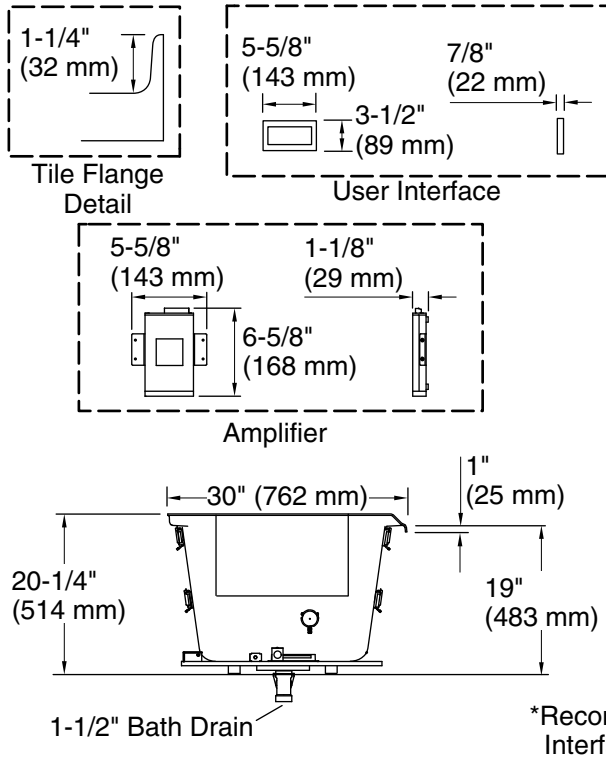

### Required Electrical Service

One circuit required, protected with Class A Ground-Fault Circuit-Interrupter (GFCI). Outside North America, this device may be known as a Residual Current Device (RCD).

Amplifier, Heated Surface: 120 V, 15 A, 50/60 Hz

### Technical Information

All product dimensions are nominal.

Drain location: Right  
 Basin area, bottom: 42-3/8" x 20" (1076 mm x 508 mm)  
 Basin area, top: 54-3/8" x 24-5/16" (1381 mm x 618 mm)  
 Weight: 85 lbs (38.6 kg)  
 Minimum floor load: 50 lbs/ft<sup>2</sup> (244.1 kg/m<sup>2</sup>)  
 Water depth: 15-1/16" (383 mm)  
 Water capacity: 59.8 gal (226.4 L)  
 Electrical component rating:  
 Amplifier: 120 V, 1.1 A, 50/60 Hz  
 Heated Surface: 120 V, 0.5 A, 50/60 Hz, 65 W  
 Amplifier channels: 2 at 15 W per channel  
 2 at 30 W per channel

### Notes

Measure your actual product for rough-in details.

Install this product according to the installation instructions.

The hot water supply should be 70% of the capacity of the bath or greater. Installations will vary.

Kit is required for under-mount installations (sold separately).

Control amplifier fits 16" (406 mm) center studs. 25' (7.6 m) cables are included.

**IMPORTANT!** Due to BLUETOOTH signal overlap, installations of multiple baths within 50 ft (15.2 m) of each other will require special order product. Please contact your dealer, showroom, or sales representative for ordering assistance.

ADA compliant when installed to the specific requirements of these regulations.